

Pipe, Conduit & Tube Clamps

PIPE, CONDUIT & TUBE CLAMPS

P1100 SERIES

FOR RIGID STEEL CONDUIT OR SCHEDULE 10, 40, 80 STEEL PIPE

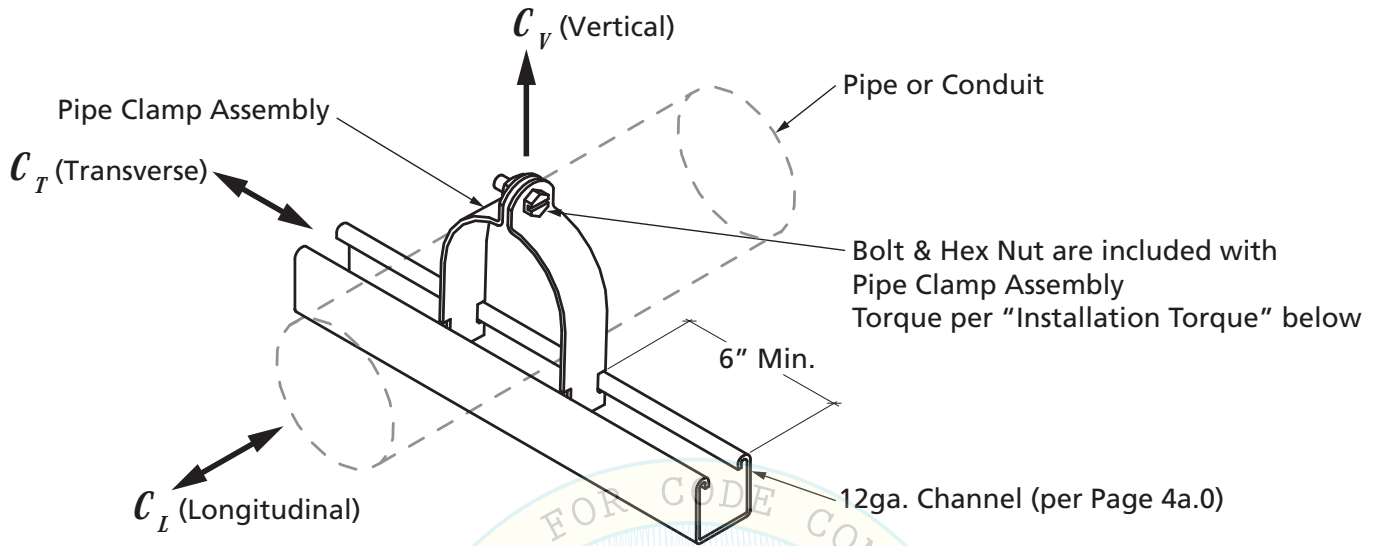

P1100 Series Pipe Clamps - Sch. 10, 40, 80 Pipe, RMC Conduit

Pipe Clamp Part Number	Nominal Pipe Size	Maximum Horizontal F_p Force (lbs)			Installation Torque (ft-lbs)
		C_V Vertical	C_T Transverse	C_L Longitudinal	
P1111*	1/2"	1,285	350	315	6
P1112*	3/4"	1,940	310	390	6
P1113*	1"	1,940	310	390	6
P1114*	1 1/4"	1,940	310	390	6
P1115*	1 1/2"	1,940	310	390	11
P1117	2"	2,720	480	825	11
P1118	2 1/2"	2,090	360	730	11
P1119	3"	2,090	360	730	11
P1120	3 1/2"	2,090	360	730	19
P1121	4"	2,090	360	730	19
P1123	5"	2,090	360	525	19
P1124	6"	2,090	360	525	19
P1126	8"	3,555	1,180	525	19

Notes:

- 1) See Page 5d.4 for full product specifications.
- 2) * Schedule 40 or heavier Pipe or RMC Conduit only



16100 S. Lathrop Ave
Harvey, IL 60426
Toll-Free: (800) 882-5543

www.unistrutseismic.com

Structural Engineer: Rami Elhassan
California SE No. 3930

Page:

5d.1