

Typical Connection Details

DETAIL 5A.5-1: TYPICAL THREADED ROD CONNECTION TO STRUT WITH BRACE

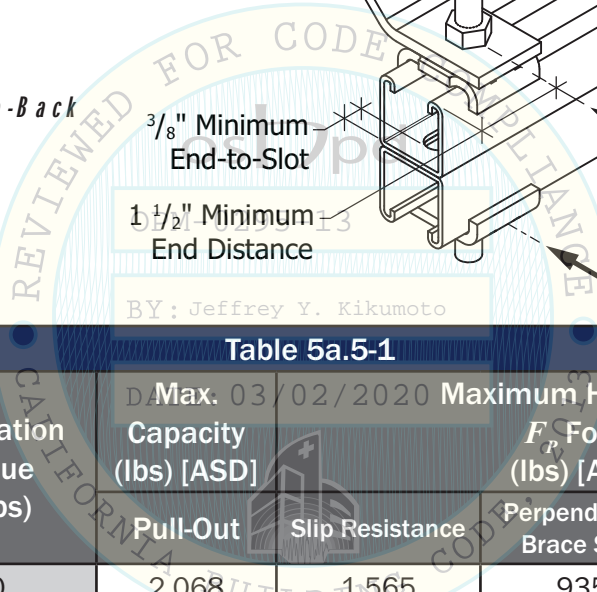
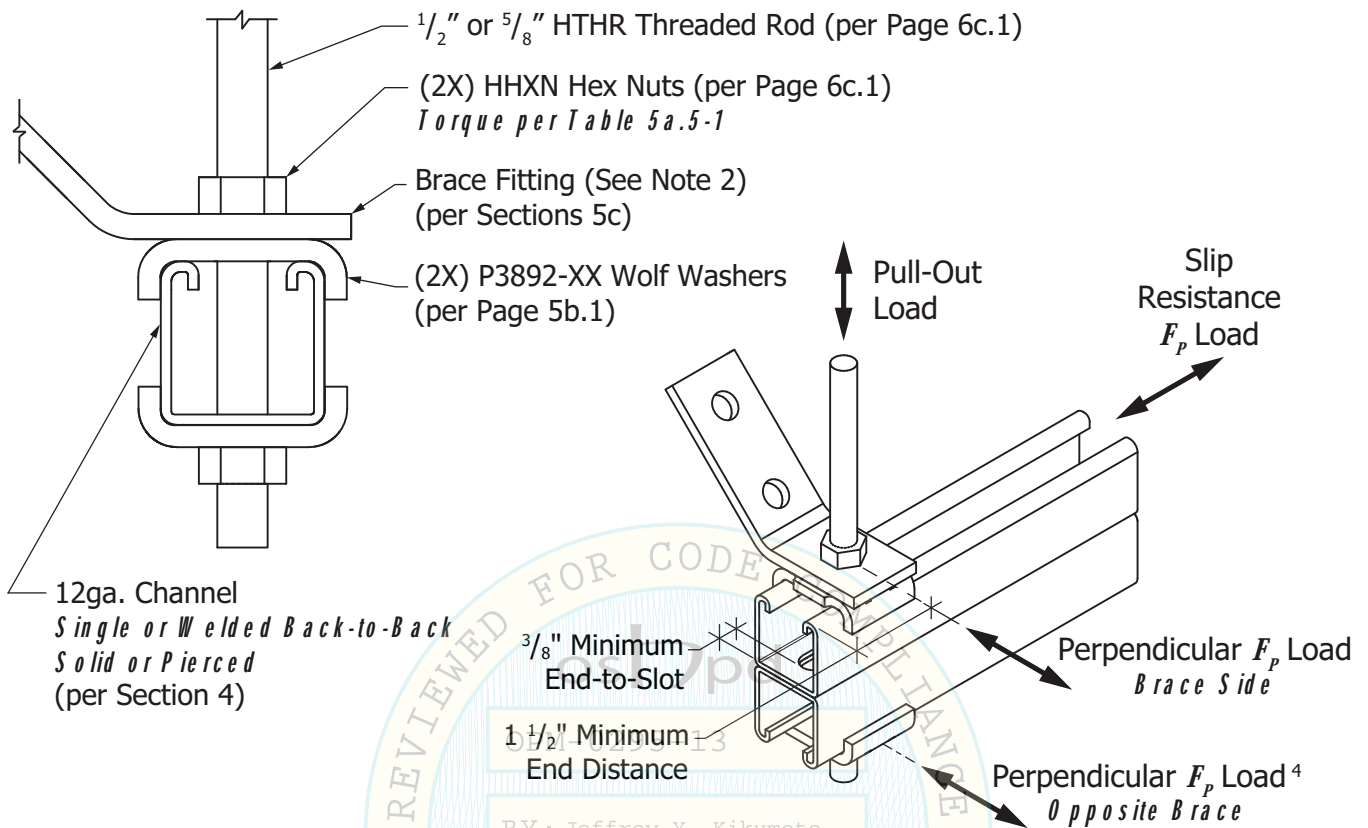

BY: Jeffrey Y. Kikumoto

Table 5a.5-1

Rod Size	Installation Torque (ft-lbs)	Maximum Horizontal F_p Force (lbs) [ASD]			
		Pull-Out	Slip Resistance	Perpendicular Brace Side	Perpendicular ⁴ Opposite Brace
1/2"	60	2,068	1,565	935	640
5/8"	73	2,605	1,565	935	640

Notes:

- 1) Capacities listed in Table 5a.5-1 are for this connection only with the brace attached to the open side of the channel. Fittings, Channel and other component capacities must also be considered.
- 2) The fitting may be oriented in a transverse or longitudinal (as shown) orientation. A typical transverse connection is shown on Detail 5b.2-1. A max of two fittings may also be stacked at this connection to accommodate braces in both directions.
- 3) Refer to Section 6D for Rod Stiffening.
- 4) When used with P1001, P5501 or P5001 channel and a perpendicular load is applied on the opposite side of the channel from the brace. The total of the perpendicular loads at the Brace Side and Opposite Side must not exceed 935 lbs.



16100 S. Lathrop Ave
Harvey, IL 60426
Toll-Free: (800) 882-5543

www.unistrutseismic.com

Structural Engineer: Rami Elhassan
California SE No. 3930

Page:

5a.5